

Induction Equipment Cooling Package

Aqua-Vent®

Recirculating Cooling Water System for Induction Equipment

- Power Supplies
- Transformers
- Generators
- Inductors
- Rectifiers

The electromagnetic field generated by an induction coil will interact with dissolved minerals (especially iron) in the cooling water, causing them to come out of solution in the critical areas of your induction equipment. These deposits cause equipment to run hot, accelerate corrosion and can completely clog cooling passages.

The NFP Series Non-Ferrous (*i.e.* no iron) cooling system is designed to isolate plant water from your induction equipment, preventing scale build up and premature equipment failure.

NFP Series Non-Ferrous Plate & Frame System

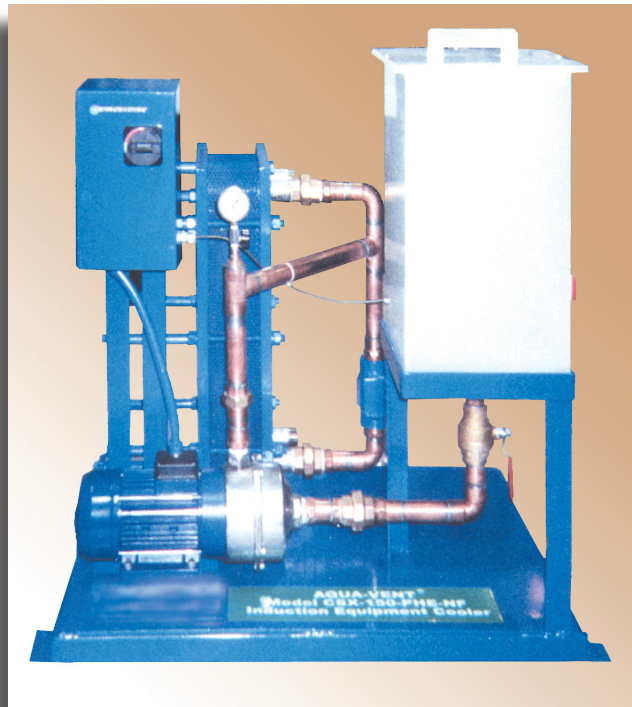

The Aqua-Vent® NFP-80 Non-Ferrous Cooling System with Thermostatic Mixing Valve and Tank Level Switch. Designed to provide 35 gpm at 80 psi and a cooling capacity of 80 kW.

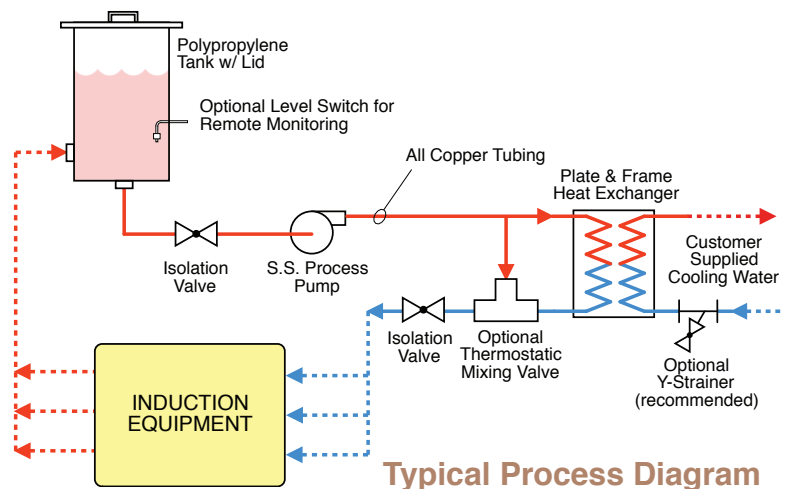

Compact • Reliable • Low Cost

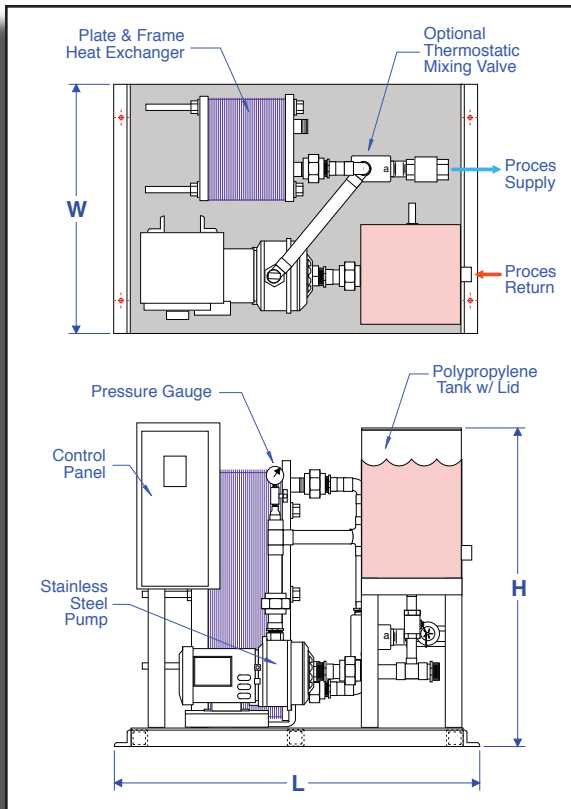

- ◆ Completely Non-Ferrous Design
- ◆ Isolates Induction Cooling Water from Raw Plant Water
- ◆ Eliminates Fouling & Corrosion
- ◆ Greatly Extends Equipment Life
- ◆ Compact Unitized Design
- ◆ Pre-Piped and Wired
- ◆ Quiet Operation

OPTIONAL FEATURES

- Tank Low Level Switch
- Thermostatic Mixing Valve
- Self-Op. Temperature Regulating Valve
- Stainless Steel Tank
- CPVC Plastic Piping
- Remote Operation

CAPACITIES and DIMENSIONS

Ratings are based upon service water supplied to plate & frame heat exchanger at 85°F. Dimensions are subject to change. Consult factory for certified drawings and cooling capacities at other flow and temperature conditions.

Model No.	Capacity		Pump HP	Tank Gal	Water Rqmt.		Inlet/Outlet Size NPT	Dimensions LxWxH (In.)	Weight Lbs.
	GPM	kW			GPM	°F			
NFP-20	10	20	2.0	11	10	85	1"	24" x 36" x 43"	425
NFP-40	20	40	2.5	14	20	85	1 1/2"	30" x 40" x 48"	460
NFP-80	35	80	4.0	14	35	85	1 1/2"	30" x 40" x 48"	480
NFP-120	50	120	7.5	33	50	85	2"	30" x 48" x 48"	520
NFP-160	65	160	7.5	33	65	85	2"	30" x 48" x 48"	550
NFP-240	95	240	15.0	42	95	85	2 1/2"	36" x 60" x 48"	610
NFP-320	125	320	15.0	42	125	85	2 1/2"	36" x 60" x 48"	640
NFP-400	155	400	15.0	59	155	85	3" Flg.	36" x 72" x 48"	690
NFP-480	185	480	15.0	59	185	85	3" Flg.	36" x 72" x 48"	720



3232 Adventure Lane
Oxford, MI 48371
1-800-525-8173
Fax (248) 969-3401
www.drycoolers.com

ALSO AVAILABLE from Dry Coolers

- Evaporative cooling tower systems
- Air and water cooled refrigerant chillers
- Non-ferrous air cooled central systems

Complete systems are pre-engineered and pre-packaged. Take the headaches out of your process cooling while saving money on water and sewer costs.

