

RepoTherm™

Waste Heat Recovery Units

Gas-to-Liquid Heat Exchangers

A modular approach to waste heat recovery from hot exhaust stacks keeps costs low and simplifies point-of-use installation. Removable coverplates provide easy access for inspection and mechanical cleaning of finned tubes if necessary. Damper controls regulate gas flow and temperature as required. A perfect solution for pre-heating boiler feed water, parts washers or rinse tanks. These system upgrades qualify for many government energy efficiency incentives. Make it pay to go green!

Pumps, heat exchangers and temperature controls are optionally available to complete the system.

Dry Coolers can meet almost any specification with a standard or custom built heat transfer package. Our knowledgeable application engineers are ready to assist you in designing an efficient system for your process.

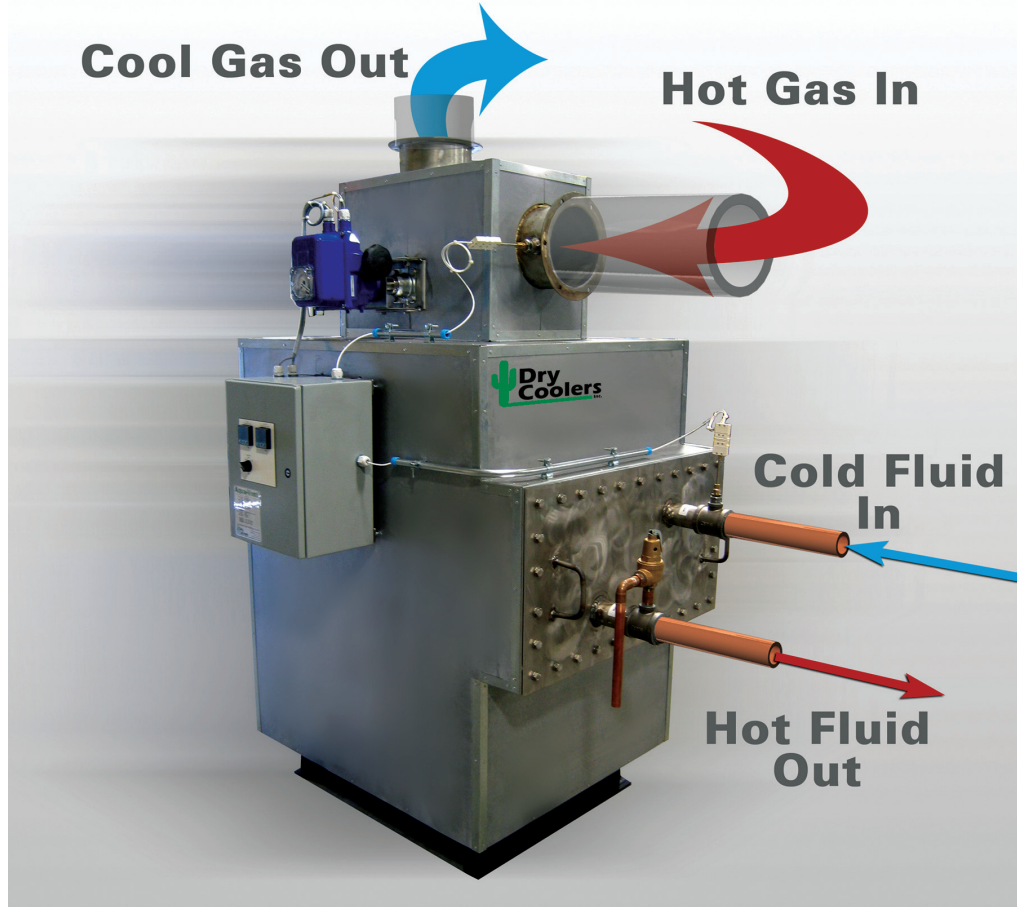

Designed specifically for high temperature industrial gas streams, HRU heat transfer packages incorporate state of the art features optimized by 3-D solid modelling for the ultimate in reliability and maintainability.

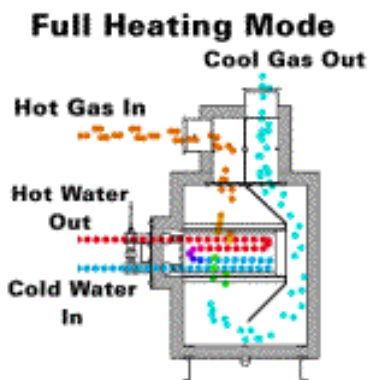

MAJOR DESIGN FEATURES

- Automatic damper-controlled gas flow
- Operating temperatures to 750°F
- Removable coverplate for tube bundle access
- Slide-out finned coil heat exchanger for easy access
- All stainless steel heat transfer surfaces
- Fully shielded and insulated construction
- Engineered to handle thermal expansion

Good Reasons to get a Heat Recovery Unit— Rapid Payback, Reliability and Energy Savings

Model HRU-800 shown - custom models available.

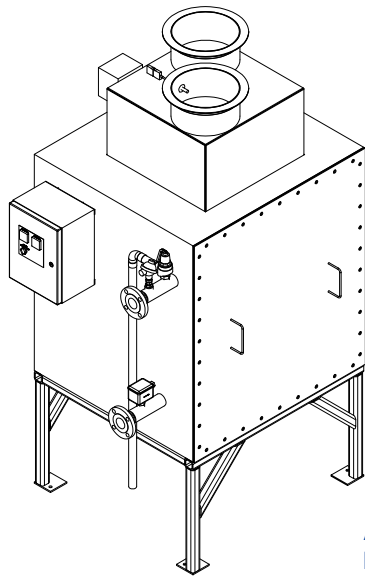

Temperature controller automatically adjusts damper for capacity control

All stainless steel tube bundle and fins. Wide fin spacing resists fouling and facilitates cleaning

Insulated housing

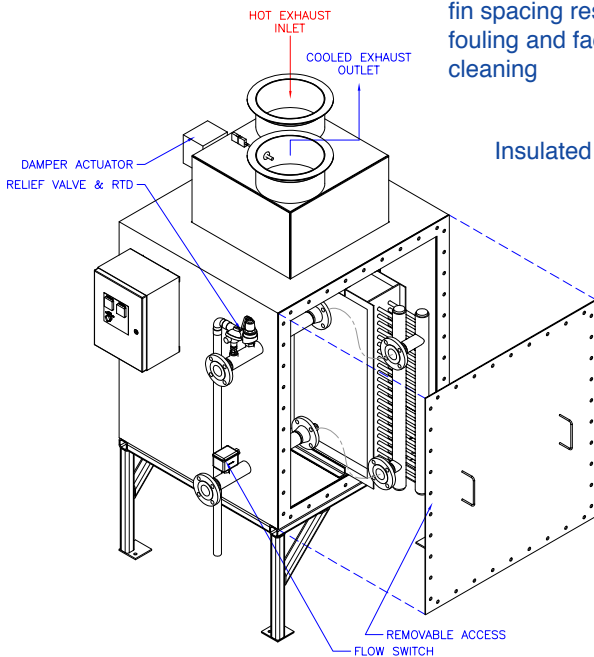

Heat exchanger slides out of housing for easy maintenance

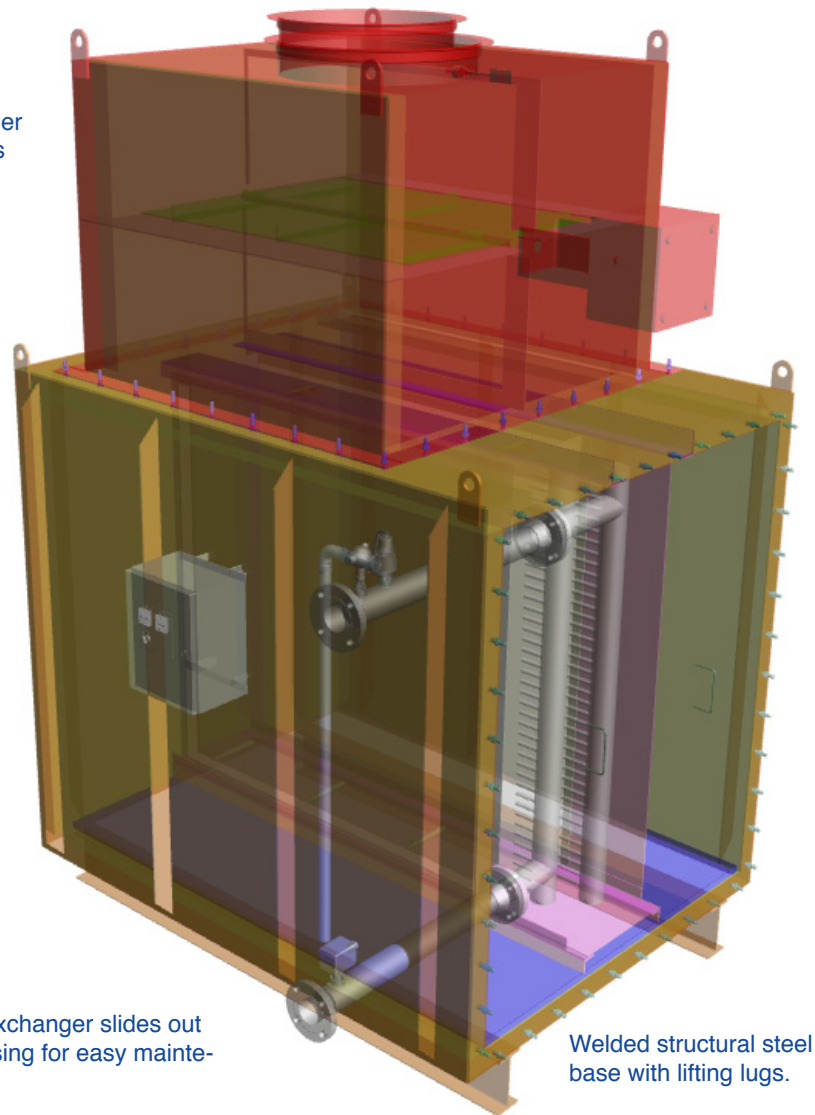

Flanged Fluid Connections

Welded structural steel base with lifting lugs.

Due to the many variables encountered in heat recovery processes, we deem it not useful to publish performance data. Please consult our sales staff for a quick computerized selection and quotation. Call us or email info@drycoolers.com



575 South Glaspie St.
Oxford, MI 48371
1-800-525-8173
Fax (248) 969-3401
www.drycoolers.com

ALSO AVAILABLE

Standard Cooling Systems for:
Vacuum Furnaces • Induction • Convection Fans
Packaged Pumping Stations and Control Systems
Chillers • Cooling Towers • Heat Exchangers