



Solids Removal for Cooling Towers

CyClean™ SOLIDS SEPARATOR

Your Cooling Tower is a Giant Air Washer!

The fan on a cooling tower draws in thousands of cubic feet per minute of outside air that contains sand, dust, insects, and fibers from vegetation. These airborne contaminants mix with the process cooling water and eventually these suspended particles find their way into heat transfer surfaces. After a period of time these surfaces become fouled and insulated causing equipment to run hotter until replacement or repair is necessary.

By removing 98% of these suspended solids mechanically, fouling is greatly reduced and chemical water treatment and bleed from the system can be reduced significantly.

Full stream filtration protects the system from dirt deposits such as winds blowing over newly plowed fields, chunks of scale eroding from steel pipe or foreign deposits encountered by adding new piping to an existing system.

By utilizing an optional purge receptacle, expensive treated process water is not wasted in the purge cycle. A small continuous flow of dirt laden process water removed by the separator is filtered and contained in the receptacle while the clean water is returned to the cooling system. The receptacle can then be isolated for easy contaminant removal without interrupting the process water flow and zero discharge to the sewer.

The key to good filtration is to provide a system where the dirt laden water can enter the suction of the pump that discharges into the CyClean™ separator for maximum filtration of the system. If the solids can be kept in suspension, they will eventually enter the suction of the pump and then be filtered by the separator—before they foul your equipment.

CyClean Separator with Bag Filter Purge Vessel



CyClean™ CYB-400 4" centrifugal separator with 2" bag filter for full stream cleaning of 350 GPM of cooling tower process water. Features zero water discharge and easy solids removal without interrupting system operation.

Typical Process Diagram

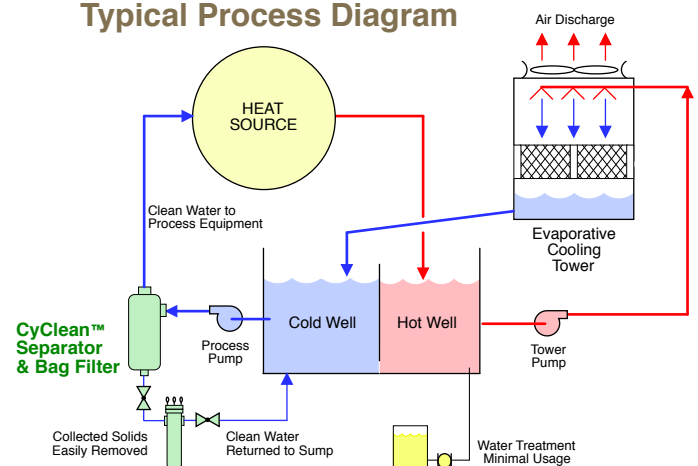

CyClean™ — Simple • Reliable • Low Cost

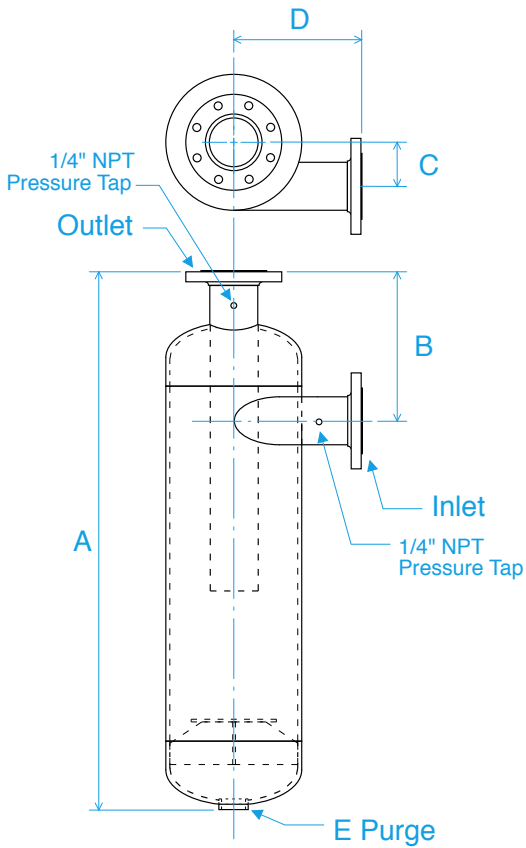

CyClean™ Centrifugal Separators

- REDUCE Fouling on heat exchangers
- REDUCE Chemical water treatment cost
- REDUCE Water usage (less tower bleed required)

- ◆ Works by Centrifugal Force
- ◆ No Moving Parts
- ◆ No Wasted Water - Zero Discharge
- ◆ Removes 98% of Suspended Solids
- ◆ Full Stream Protection

OPTIONAL FEATURES

- Bag Filter Purge Receptacle
- Clean Out Port
- Differential Pressure Gauge
- Stainless Steel or other Alloy Construction

CAPACITIES and DIMENSIONS

Cv ratings are based upon water. Pressure drop at a given flow in psi = (gpm/Cv)². Dimensions are subject to change. Consult factory for certified drawings. Consult factory for fluids other than water or for larger sizes which are available upon request.

CyClean Model	Inlet/Outlet Size	Flow Range GPM	Dimensions (Inches)					Cv GPM	Weight lbs.
			A	B	C	D	E		
CY-150	1 1/2" NPT	45 - 75	30	7	2 1/2	6	3/4" NPT	26	65
CY-200	2" NPT	60 - 105	34	7 3/4	4	8	1" NPT	35	100
CY-250	2 1/2" FLG	85 - 160	34	8 1/4	4	8	1" NPT	48	120
CY-300	3" FLG	160 - 300	40	11 3/4	3 5/8	12	1 1/2" NPT	97	170
CY-400	4" FLG	260 - 450	43	14 1/4	4	14	1 1/2" NPT	152	290
CY-500	5" FLG	340 - 600	50	15 1/4	3 1/2	14	1 1/2" NPT	193	340
CY-600	6" FLG	600 - 1100	57	16 1/4	3 3/4	15	1 1/2" NPT	352	410
CY-800	8" FLG	1050 - 1800	69	17 3/4	4 3/4	17	2" NPT	590	650
CY-1000	10" FLG	1550 - 2650	82 1/2	20	5 5/8	19	2" NPT	880	930
CY-1200	12" FLG	2050 - 3500	96	22	5 5/8	20	2 1/2" NPT	1175	1240
CY-1400	14" FLG	2800 - 5000	104	23	8	23	2 1/2" NPT	1610	1600



3232 Adventure Lane
Oxford, MI 48371
1-800-525-8173
Michigan (248) 969-3400
Fax (248) 969-3401
www.drycoolers.com



ALSO AVAILABLE from Dry Coolers

- Evaporative cooling tower systems
- Air and water cooled refrigerant chillers
- Air cooled heat exchange systems

Complete systems are pre-engineered and pre-packaged. Take the headaches out of your process cooling while saving money on water and sewer costs.