

Omni-Chill[™] Process Chiller Systems



 **Dry
Coolers**
Inc.

Our Commitment to Quality

Every Omni-Chill™ is thoroughly tested and run-off before shipment to ensure a smooth startup. Dry Coolers is ISO 9001:2000 certified and we have demonstrated our commitment to quality and reliability in thousands of successful installations worldwide. Our engineers will help select the best system for your

application and site conditions. We have solutions for almost any challenge including high ambient air temperatures up to 122°F (50°C) or ambient air as low as -25°F (-31°C). Our ability to ensure continuous operation in dirty manufacturing environments with rapid thermal cycles is superior to commercial

grade equipment. We offer emergency backup cooling for mission-critical systems, and hybrid designs using air cooled heat exchangers or evaporative cooling towers for increased efficiency. We are proud of our reputation for innovation and we constantly evaluate and adopt state-of-the-art technology.

Standard Options

- R-22, R134a, R407C, R507
- Temperatures from -20°F to 90°F
- Scroll, Reciprocating, or Screw Compressors
- Remote Operator Interface
- Ethernet Connectivity via Browser
- Indoor or Outdoor Models - Split Systems
- Non-ferrous Wetted Components
- Cleanable Condenser Filters
- Construction to meet UL, CSA, CE

Custom Options

- Various Communication Protocols
- Explosion-Proof Construction
- Specific Name-Brand Components
- Specialty Fluids or Gases
- Temperature Control Units (Heating/Cooling)
- Warm Air or Water Heat Recuperation
- High Pressure Pumping Systems

“Free” Coolers

- Cool with ambient air in cold climates
- Offloads compressors in winter
- Saves energy
- Fully automatic operation
- Saves wear and tear on compressor



50 Ton Outdoor Air Cooled Chiller with Remote and Local Operator Interface



Precision Temperature Control Unit Programmable Heating and Cooling with adjustable Ramp & Soak $\pm 0.5^{\circ}\text{C}$



15 Ton Synthetic Oil Cooler for Semi-conductor Manufacturing Process

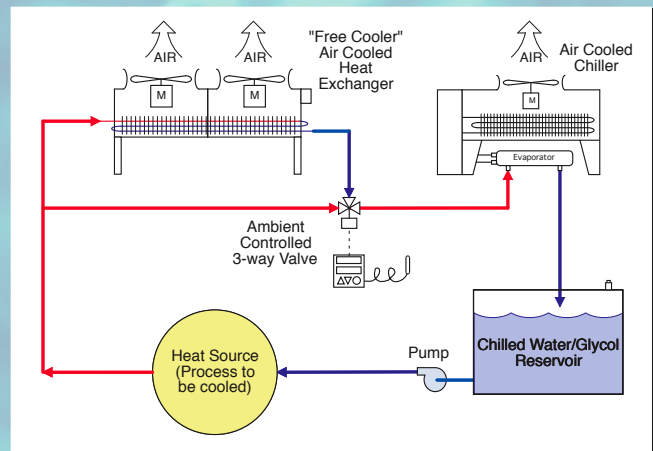

3-Way valve bypasses air cooled exchanger when ambient air is too warm

Omni-Chill™

The Right Choice

Purchasing

You'll purchase a complete skid-mounted system designed by experts. It's headache-free one-stop purchasing.

Engineering

Save hours of engineering and fabrication time. With an Omni-Chill cooling system from Dry Coolers you get the right design, prudently engineered with quality components, and flexibility to suit your application.

Installation

All necessary valves, controls and gauges are pre-installed, so in-plant piping is streamlined. Running field wiring from the power supply and piping to your equipment typically completes the installation. A thorough, yet easy-to-read installation, operation and maintenance manual is prepared for each order.



Other Products Available



Air Cooled Heat Exchangers



Evaporative Cooling Towers



Plate Heat Exchangers



Filtration Equipment



For immediate assistance and specific product bulletins call us Toll Free at 1-800-525-8173 or visit our web site at www.drycoolers.com

3232 Adventure Lane Oxford, MI 48371 USA 248-969-3400 Fax 248-969-3401

ISO 9001:2000
REGISTERED